



# Air-Grip™ 2 Industrial Pneumatic-Hydraulic Rivet Tool

Model Air-Grip™ 2 is an industrial production Air Rivet Tool with Robust **Forged Aluminum Alloy Oil Cylinder**, **Ergonomically Designed Handle**, **High Traction Force 9,000 N or 2,000 Lbf** and **Long Stroke 18 mm or 0.71"**, **Innovative Quick-Change Type Jaw Case Assembly**, very ideal for Intensive fastening **2.4 ~ 4.8/5.0 mm or 3/32" ~ 3/16"** all **HSS (High Strength Structural)**, all **Structural** (like \*Monobolt®, \*Interlock®, \*Hemlok®, \*Magna-Lok®, \*Auto-Bulb®, etc.) and all **Standard Blind Rivets** simply by exchanging interchangeable Nosepieces.

## SPECIFICATIONS

- **Traction Force:** 9,000 N at 6.2 bar or 2,000 Lbf at 90 psi compressed air pressure
- **Stroke:** 18 mm or 0.71"

## FEATURES

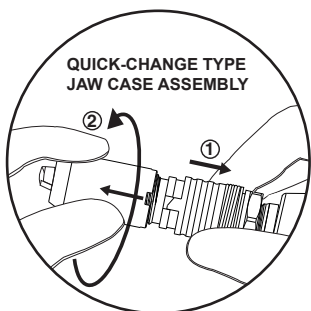

- **Innovative Quick-Change Type Jaw Case Assembly** for fast cleaning or replacing inside parts (Jaws, Jaw Pusher, etc.) just by hand without any wrenches.

- **Robust Forged Aluminum Alloy Oil Cylinder with Titanium Color finish and High Strength Aluminum Alloy Air Cylinder** for strength, durability and valuable look.

- **Mirror finish on the Inner Walls of Oil Cylinder and Air Cylinder** for precision and wear resistance.

- **Hard Chrome Plating and Mirror finish on the Rods of Oil Piston and Air Piston** for fast operation and long operation life.

## RIVETING CAPACITY

Rivet Diameter	Rivet Material	Aluminum	Steel	Stainless Steel (Inox)
2.4 mm or 3/32"		●	●	●
3.0/3.2 mm or 1/8"		●	●	●
4.0 mm or 5/32"		●	●	●
4.8/5.0 mm or 3/16"		●	●	●
4.0 mm or 5/32" Structural/HSS Rivets		●	●	●
4.8/5.0 mm or 3/16" Structural/HSS Rivets		●	●	●

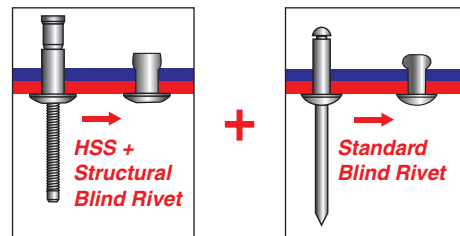

- **Spent Mandrel Container for visible check** protects operator's eyes and keeps working places clean.

- **Smart Ergonomically Designed Handle and PAHs-Free (non-toxic to hand skin) Plastic Soft Grip** offer balanced, safe and comfortable operation.

- **Innovative Shock-Reducer Design™, Noise Silencer Design™, Rivet Size Hole Gauge Design™, Nosepieces Storage Design™, Oil Refill Hole Design™, Twin Air Inlets Design™, 360° Double Swivel Air Fitting, All Metallic Structure.**

## DIMENSIONS & WEIGHT

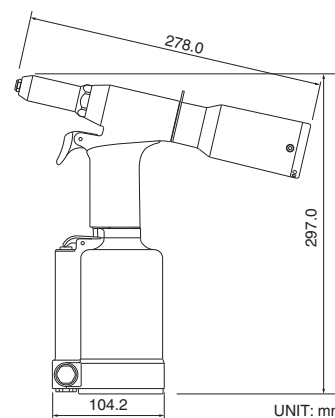

- **Weight:** Approx. 1.99 Kg or 4.39 Lb

REMARKS: • Monobolt®, Interlock® and Hemlok® are the registered trademarks of AVDEL. Special Monobolt® Nosepieces are available.  
 • Magna-Lok® and Auto-Bulb® are the registered trademarks of HOWMET AEROSPACE.  
 • HSS (High Strength Structural) Blind Rivets are widely used in the German cars to fasten chassis and body together and to build the car carriage. The Mandrel Diameters of HSS Blind Rivets are bigger than the Structural and Standard Blind Rivets' Mandrel Diameters, and the Special HSS Nosepieces are available.